

© 2013 Essentra Components. All rights reserved.
 Registered in England, Company No. 547495.
 Registered Office: Essentra plc
 Langford Locks, Kidlington, Oxford, OX5 1HX

Condition of Sale can be found on our website: essentra.com.

Essentra Components does not warrant that the files will be error free and may create new versions ("Upgrades") at any time, which may correct such errors. Essentra Components has no obligation to notify you of such upgrades. Any upgraded file will be published to the website, when it becomes available.

You are not permitted to load any of the files on to a network server for the purposes of distribution to one or more other computer(s) on that network or to effect such distribution. Essentra Components shall not be liable for any loss or damage whatsoever or however caused, arising directly or indirectly from the use of the files.

UNCONTROLLED COPY

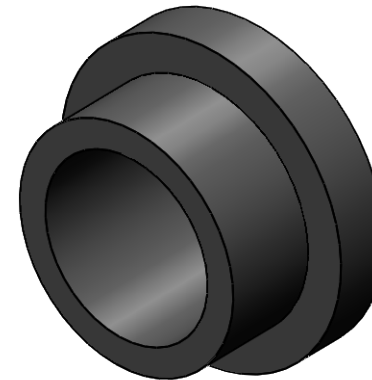
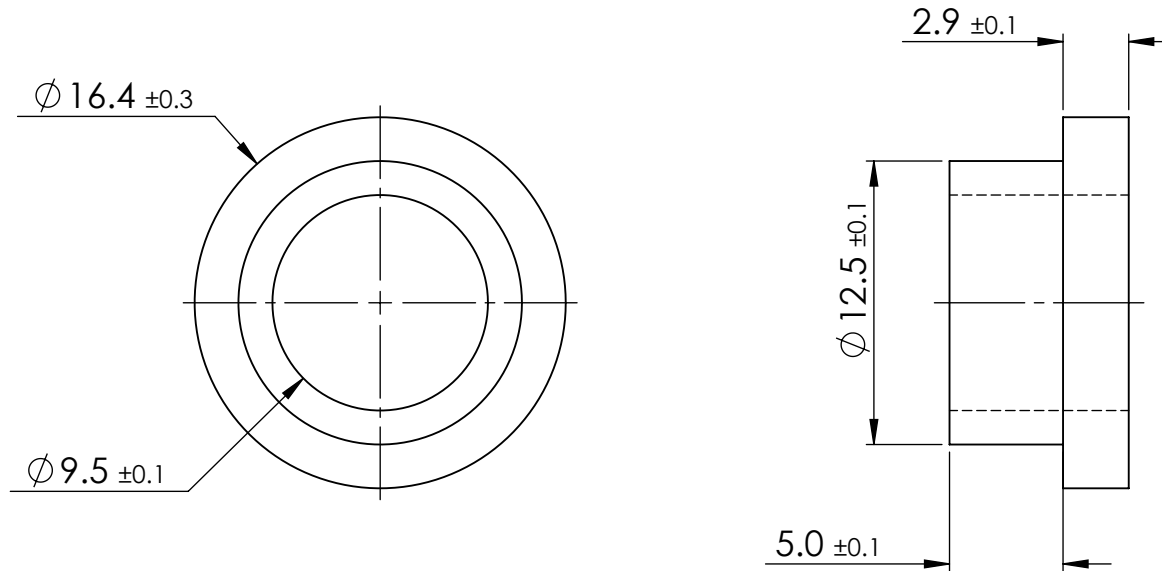

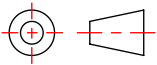
STATUS		APPROVED DRAWING	
UNLESS OTHERWISE STATED			
ALL DIMENSIONS IN mm		DO NOT SCALE	
LINEAR TOLERANCE		THIRD ANGLE PROJECTION	
SIZE	(0) (0.0) (0.00)	 ANGULAR TOLERANCE ± 0.5 DEGREES UNSPECIFIED RADII 0.25mm DRAFT ANGLE 0.5 DEGREES DIMENSIONS IN PARENTHESIS () ARE FOR REFERENCE ONLY	
0-10	± 0.5 ± 0.15 ± 0.10		
>10-30	± 0.5 ± 0.20 ± 0.15		
>30-50	± 0.5 ± 0.30 ± 0.20		
>50-100	± 0.8 ± 0.50 ± 0.25		
>100-200	± 1.5 ± 0.80 ± 0.40		
>200-300	± 2.0 ± 1.20 ± 0.80		
>300-500	± 3.0 ± 2.00 ± 1.00	ITEM CODE	
>500	± 5.0 ± 3.00 ± 1.50	20468538	20/03/2025
LEGACY CODE	12SWS1202B	PA66	MATERIAL
		BLACK	COLOUR
		-	FINISH
TITLE:			
SHOULDER WASHER			
-			
DWG. No.		SCALE	ISSUE
20468538		3:1	1
		SHEET	1 of 2

Essentra Components does not warrant that the files will be error free and may create new versions ("Upgrades") at any time, which may correct such errors. Essentra Components has no obligation to notify you of such upgrades. Any upgraded file will be published to the website, when it becomes available.

You are not permitted to load any of the files on to a network server for the purposes of distribution to one or more other computer(s) on that network or to effect such distribution. Essentra Components shall not be liable for any loss or damage whatsoever or however caused, arising directly or indirectly from the use of the files.

UNCONTROLLED COPY

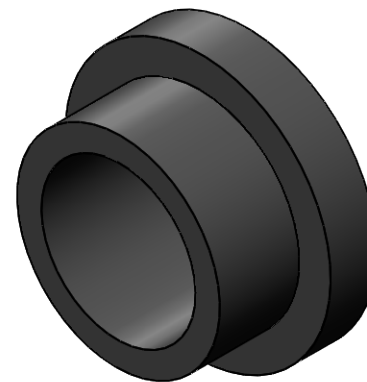
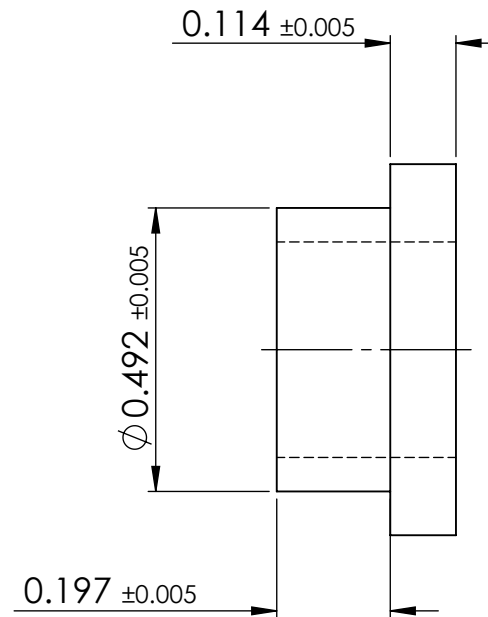
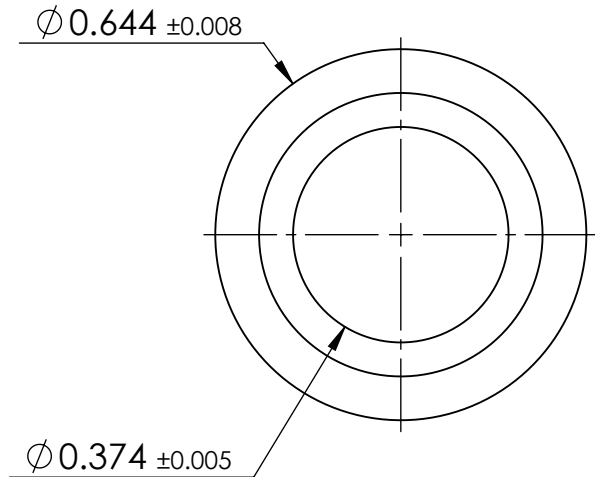

STATUS **APPROVED DRAWING**

UNLESS OTHERWISE STATED

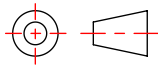
ALL DIMENSIONS IN inches			DO NOT SCALE
LINEAR TOLERANCE			THIRD ANGLE PROJECTION
SIZE	(0.00)	(0.000)	(0.0000)
0 - 0.394	±0.020	±0.006	±0.004
>0.394 - 1.181	±0.020	±0.008	±0.006
>1.181 - 1.969	±0.020	±0.012	±0.008
>1.969 - 3.937	±0.031	±0.020	±0.010
>3.937 - 7.874	±0.059	±0.031	±0.016
>7.874 - 11.811	±0.079	±0.047	±0.031
>11.811 - 19.685	±0.118	±0.079	±0.039
>19.685	±0.197	±0.118	±0.059
			
			ANGULAR TOLERANCE ±0.5 DEGREES UNSPECIFIED RADII 0.25mm DRAFT ANGLE 0.5 DEGREES DIMENSIONS IN PARENTHESIS () ARE FOR REFERENCE ONLY

ITEM CODE	20468538	20/03/2025	CREATE DATE
LEGACY CODE	12SWS1202B	PA66	MATERIAL
		BLACK	COLOUR
		-	FINISH

TITLE:
 SHOULDER WASHER
 -

DWG. No.	20468538	SCALE	ISSUE
		3:1	1
		SHEET	2 of 2